

Noctua LGA1366/LGA1156/1155 Installation Manual

Vielen Dank, dass Sie sich für Ihr LGA1366 oder LGA1156/1155 System für einen Noctua-Kühler entschieden haben.

Das NM-I3 SecuFirm2™ Montage-Kit für LGA1366 und LGA1156/1155 ist mit den folgenden CPU-Kühlern kompatibel: NH-C12P, NH-U12F, NH-U12P, NH-U12P SE1366, NH-U9B, NH-U9F, NH-U12, NH-U9.

Dieses Handbuch führt Sie anhand des Beispiels eines NH-U12P Kühlers Schritt für Schritt durch den Installationsprozess, der für alle Modelle gleich ist.

Should you encounter any difficulties, please check the FAQs on our website and don't hesitate to contact our support team at support@noctua.at.

Noctua cannot be held responsible for any damage or losses caused by compatibility issues.

Multilingual versions of this manual are available on our website: www.noctua.at

Required mounting parts:



1x 3-in-1 Intel backplate



4 bolts for backplate

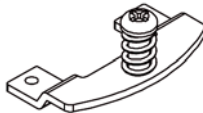

2x fastening brackets

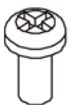

4x short screws



2x mounting bars



4x plastic spacers



4x thumbscrews

Step 1: Removing the mainboard

In case you want to use the cooler on an assembled system, you first have to remove the mainboard from the case in order to be able to install the supplied backplate.

Caution: On LGA1366 and LGA1156/1155, the supplied backplate will install over the mainboard's stock backplate, so the mainboard's stock backplate must not be taken off.

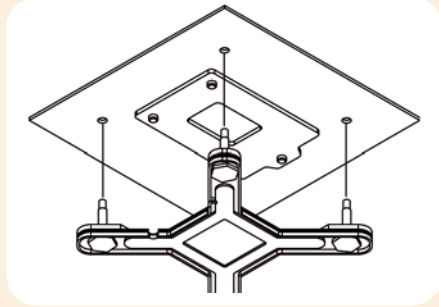

Step 2: Setting up the backplate

First put the four bolts into the holes appropriate for your motherboard's CPU socket.

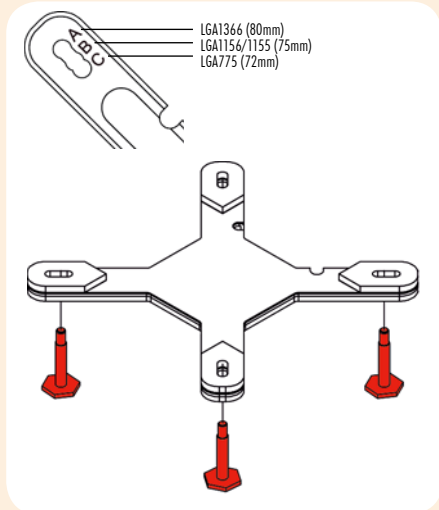

Caution: Please verify that all four bolts are put into the appropriate holes fully pushed in.

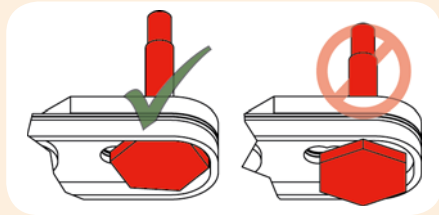

Step 3: Attaching the backplate

Place the backplate on the rear side of the mainboard so that the bolts stick through the mounting holes.

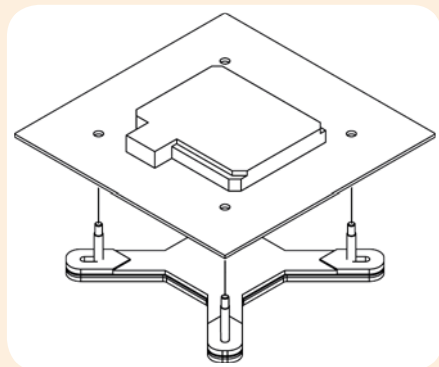

Caution: On LGA1156/1155, please make sure that the two cuts in the supplied backplate align with the screws of the motherboard's stock backplate.

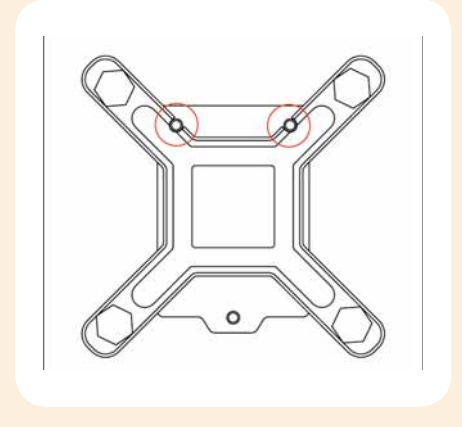

Step 4: Installing the mounting bars

First put the plastic spacers onto the bolts, then add the mounting bars.

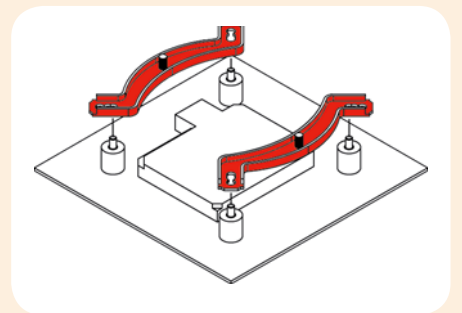
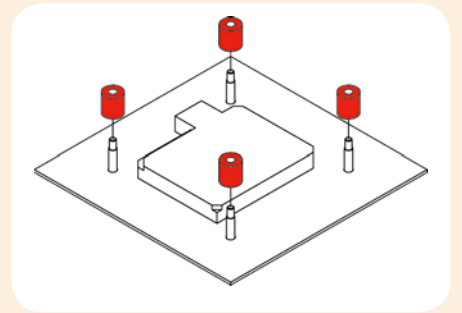

Caution: Choose the alignment of the mounting bars according to the desired final orientation of the cooler.

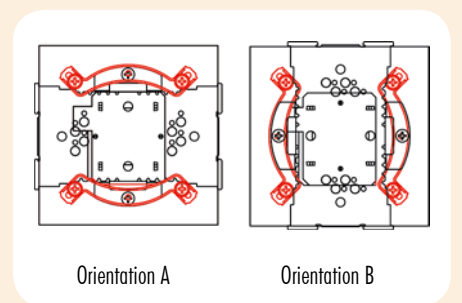

Caution: Make sure that the curved sides of the mounting bars are pointing outwards.

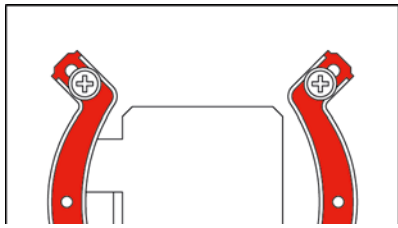

Caution: Make sure to use the correct holes on the mounting bars.

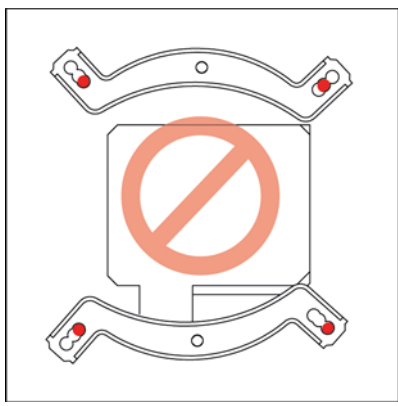

Fix the mounting bars using the 4 thumb screws.

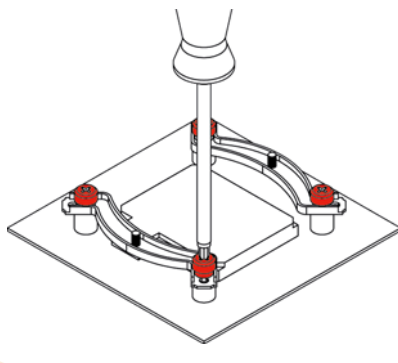

Caution: Tighten the screws until they stop.

Step 5:
Attaching the fastening brackets to the heatsink

Tightly screw the fastening brackets to the base of the heatsink using the 4 short screws.

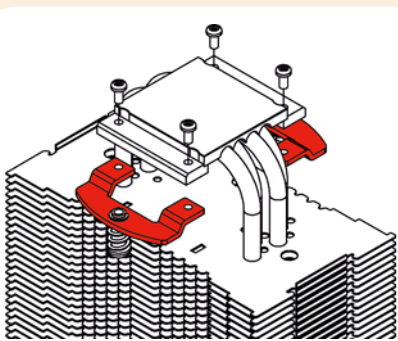

Caution: Make sure to install the fastening brackets in the correct position:

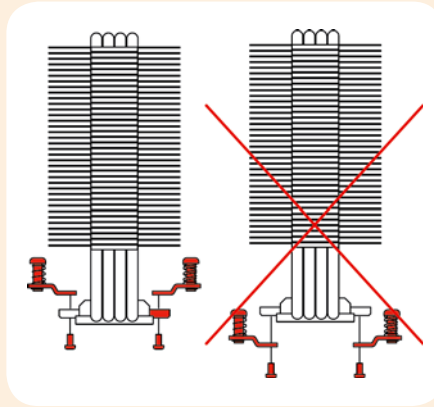

Step 6:
Applying thermal paste

If there are residual traces of thermal paste or thermal pads on your CPU, please clean them off first. Then press a small drop (4-5mm diameter) of NT-H1 onto the centre of the heat-spreader.

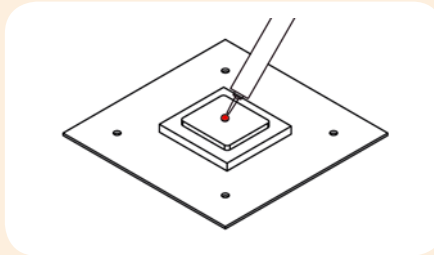

Caution: Applying too much thermal paste will lower the heat conductivity and cooling performance!

Step 7:
Fastening the heatsink to the CPU

Caution: Please take off the protection cover at the bottom side of the heatsink first!

Put the heatsink onto the CPU and screw it to the screw threads of the mounting bars.

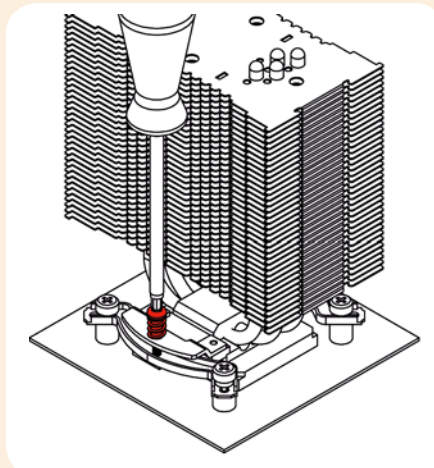

Caution: Tighten the screws until they stop.

Step 8:
Installing the fan

Install the fan as described in the manual that came with the cooler.

Warranty

Even with high-grade products and strict quality control, the possibility of defects cannot be eliminated entirely. Therefore, we aim at providing the highest possible level of dependability and convenience by offering a warranty period of 72 months and direct, fast and straightforward RMA service.

In case of warranty, you can either request RMA at your retailer or use our Direct RMA Service. For further information, please consult www.noctua.at. In order to process your RMA enquiry, we need a proof of purchase, so please don't forget to keep your invoice!

Please also note that any modifications to the cooler, fan or mounting parts will void your warranty.

Support & FAQs

For all enquiries concerning your Noctua cooler, both your retailer and the international Noctua support team at support@noctua.at are at your service.

Please also consult the FAQ section on our website www.noctua.at.